



Tea Tree Gully Gem & Mineral Club Inc. (TTGGMC)
Clubrooms: Old Tea Tree Gully School, Dowding Terrace, Tea Tree Gully, SA 5091.
Postal Address: Po Box 40, St Agnes, SA 5097.
 President: Ian Everard. H: 8251 1830 M: 0417 859 443 Email: ieverard@bigpond.net.au
 Secretary: Claudia Gill. M: 0419 841 473 Email: cjjrgill@adam.com.au
 Treasurer: Russell Fischer. Email: rfischer@bigpond.net.au

May.
Edition
2016

"Rockzette"

Tea Tree Gully Gem & Mineral Club News

In This Edition...	President's Report	Meetings, Courses & Fees.
<ul style="list-style-type: none"> Diary Dates Stop Press President's Report. Club Activities. Meetings, Courses & Fees. Ian's Canberra Rock Swap quartz purchases. Members Out and About. General Interest – Kilroy Was Here. General Interest – Fifty Shades of Chocolate. 	<p>Hi All, By the time you all read this the 'Palmer Show' will be all finished for another year. Hope the weather Gods are kind to us there. Our new lease is going to a Council meeting on May 10th. Then all we need to do after that, is sign it and pay our rent. Cheers, Ian.</p>	<p><u>Meetings (Amended for June, July and August)</u> Club meetings are held on the 1st Thursday of each month except January: Committee meetings start at 7.00 pm. General meetings - arrive at 7.30 pm for 8.00 pm start.</p>
Diary Dates	Club Activities	<p><u>Faceting</u> (times to be advised) <i>Course 10 weeks x 2 hours Cost \$20.00.</i> <i>Use of equipment \$1.00 per hour.</i></p>
2016	<p><u>Competitions</u> Competitions have been suspended indefinitely and are currently replaced with members showcasing an interesting part of their collection.</p>	<p><u>Lapidary</u> (Tuesday mornings) <i>Course 5 weeks x 2 hours Cost \$10.00.</i> <i>Use of equipment \$1.00 per hour.</i></p>
Stop Press	<p><u>Field Trips</u> No fieldtrips planned during Summer months.</p> <p><u>Library</u> <i>Librarian - Augie Gray</i> There is a 2 month limit on borrowed items.</p>	<p><u>Silver Craft</u> (Friday mornings) <i>Course 5 weeks x 2 hours Cost \$20.00.</i> <i>Use of equipment \$1.00 per hour.</i></p>
<ul style="list-style-type: none"> Thursday 5th May, 2016. Meeting Presentation by Don McColl; topic 'Harts Range, N.T.' Winter Club Meeting Arrangements At the April, 2016, Committee Meeting, it was decided to trial rescheduled times for June, July and August club meetings; a Winter Schedule as such. Therefore, on the first Thursday of June, July and August 2016, the Committee Meeting will start at 3.00pm followed by the General Meeting at 3.30pm. 	<p>When borrowing from the lending library, fill out the card at the back of the item, then place the card in the box on the shelf.</p> <p>When returning items, fill in the return date on the card, then place the card at the back of the item.</p>	<p>While some consumable materials are supplied by the club, trainees must supply any additional requirements.</p> <p>Trainees who use the club equipment (for example, magnifying head pieces, faceting equipment, tools, etc.) must return them to the workshop after usage. Trainees are also encouraged to purchase and use their own equipment.</p>
<p>The Tea Tree Gully Gem & Mineral Club Inc. is not and cannot be held responsible or liable for any personal injuries, loss or damage to property at any club activity, including, but not limited to, meetings, field trips, all crafts and club shows. An indemnity is to be signed by all participants before each and every field trip activity they attend.</p>		<p>In the interest of providing a safe working environment, it is necessary to ensure individuals using the workshops follow the rules set out in <i>Policy No. 1 - 20/11/2006</i>.</p> <p>It is necessary that <i>Health and Safety</i> regulations <u>are</u> adhered to at all times.</p> <p>Trainees must ensure:</p> <ul style="list-style-type: none"> that all work stations are left in a clean and tidy state; that all rubbish is removed and placed in the appropriate bin; and where applicable, machines are cleaned and oiled. <p><i>The Tea Tree Gully Gem & Mineral Club Inc. will not be held responsible or liable for any person injured while using the club machinery or equipment.</i></p> <p><u>Club Subscriptions</u> \$25.00 Family. \$20.00 Family/Pensioner. \$15.00 Single. \$12.50 Single/Pensioner. \$10.00 Joining Fee.</p>

Ian Everard's Quartz Purchases – Part A.

Pictured here are some of Ian's purchases at the Canberra Rock Swap this year. Note the variety of quartz forms from Madagascar including amethyst sceptres and conjoined quartz crystals with a common name, 'quartz butterflies'. Other crystals have concentrated amethyst tips.

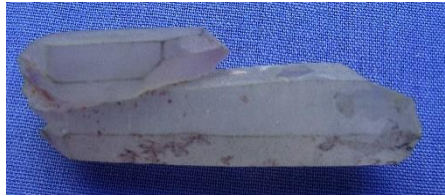
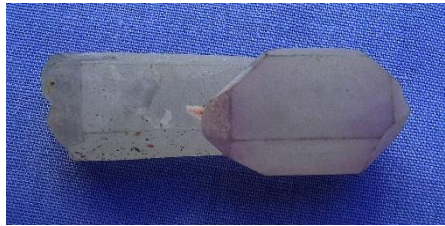



National Museum of Australia

On 9th of April, 2016, Ian, Janet and Mel visited the National Museum in Canberra. This picture gallery is a random selection of items on display...



Boy's Toys.

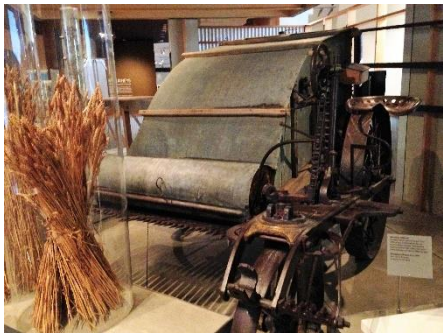

Horse drawn wheat and barley stripper.



Platypus skeleton.



A Museum window view of Lake Burley Griffin.



Flintlock pistol.



Holden - South Australia will miss this.



Indigenous Woven Baskets Northern Queensland.



Indigenous Camp Scene made predominantly from Spinifex Plant.



Studying the detail.



Big, but far from the biggest.



Federation.



Women's Hat Mould.



Women's Hat.



Portrait of Reversed History.

Canberra Deep Space Communication Complex.

On the 10th of April, 2016, Ian, Janet and Mel, visited the Canberra Deep Space Complex. This picture gallery is a random selection of items on display...



Deep Space Station 43

Directly ahead is our 'big dish' called *Deep Space Station 43 (DSS-43)*. It is the largest steerable antenna dish in the southern hemisphere and is used for two-way spacecraft communications.

DSS-43 stands 73-metre high (about 22-storeys), and the main reflector dish is 70-metres in diameter.

Two drive mechanisms move the antenna. Car-sized motors on the twin-curved gear moves the dish in elevation. To rotate the antenna it uses a 'hydrostatic bearing'. Essentially like a hovercraft, the 4,000 metric tonnes of rotating structure floats on a high-pressure layer of oil, only 0.17mm thick. The base, extends another 11-metres underground and weighs 3.5 million kilograms.

DSS-43 can transmit commands to spacecraft billions of kilometres from Earth and can receive their tiny signals which can be billions of times weaker than the power of a watch battery.



Antenna Structure

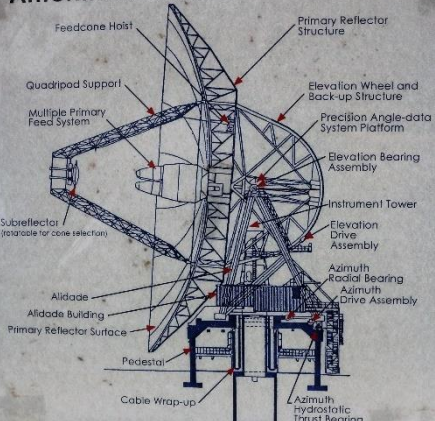

Mars Exploration Rover

1:1 Full Scale Model

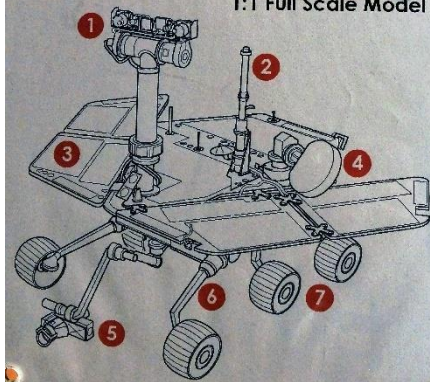

Mars Exploration Rover

The two identical rovers - Spirit & Opportunity - are the scientist's eyes, arms, and legs on Mars. Their instruments have helped to reveal Mars as a warm, wet world that could have supported life.

Major systems on the Rovers include:

1. Camera Mast: Five digital cameras that provide, infrared, stereoscopic, and panoramic images
2. Low-gain antenna for transmitting & receiving
3. Solar panels providing power to the vehicle
4. High-gain antenna for high volume data transfer
5. Robot Arm - four instruments including a drill, a microscope, and two spectrometers for analysing rock and soil
6. Rocker-bogie mobility system ("suspension")
7. Six-wheel drive system with independent steering and motor drives



APOLLO XI MOON ROCK

Display Sample: 10072,80
 Rock Type: Vesicular, interstitial basalt
 Original Mass: 447 grams
 Sample Mass: 142.25 grams
 Absolute Age: 3.8 billion years (since crystallisation of lava)

This piece of moonrock was returned to Earth during the Apollo XI mission in July 1969. It was one of about 21.5 kilograms of samples collected by astronauts Buzz Aldrin & Neil Armstrong.



Apollo XI Moon Rock.

Yass Show.

On the 10th of April, 2016, Ian, Janet and Mel, visited the Yass Show. This picture gallery is a random selection of activities and items on display...



Ian and Janet looking at farm equipment.



Portable sheep shearing plant.



Janet and Ian watch a man splitting a huge log with a wedge.



Tools requiring excessive manual labour.



Janet purchasing Alpaca Wool knitting yarn.



I can spin a better yarn than him!



We thought they were judging the cattle; no, it was the handlers.



Cattle Handling Competitions.



Waiting for the judge's decision.



Sheep judging.



Cattle Yarding Competitions.



Waiting for the next heat.



The man on the left has a 33 stroke handicap!



Wood chopping Competitions.



Nevertheless, he Still gets a second place in the heat!



Pumpkin Competition.

National Art Gallery.

On the 13th of April, 2016, Ian, Janet and Mel, visited the National Art Gallery. This picture gallery is a random selection of activities and art work on display...



'Men's Wear' – John Brack.



Janet viewing, 'Girls at School' – John Brack.



Ian viewing artwork in the Indigenous Art room.



'Gurrmirringu the Great Hunter' – David Malangi Daymirringu



'Morning Light' – Hans Heysen.

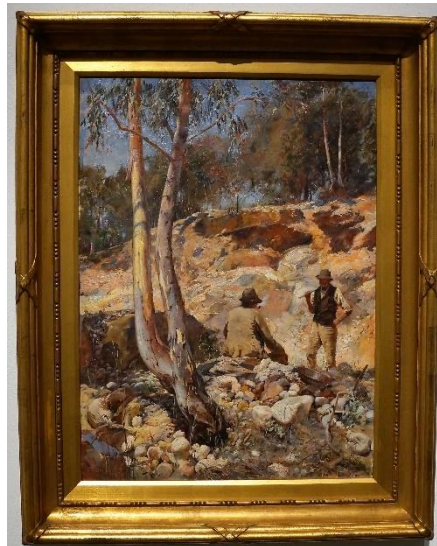

'Fossickers' – Walter Withers.



Janet in the girls only portrait room.



'Love Story' – Clifford Possum Tjapaltjarri.



Janet viewing, 'The Drover's Wife' - Russell Drysdale.

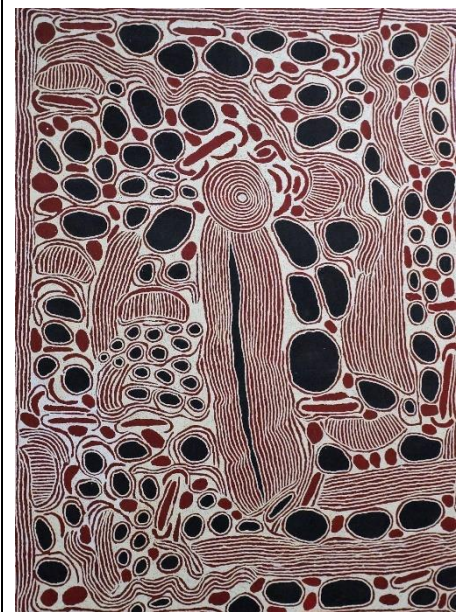

'Untitled' – Ningura Napurrula.

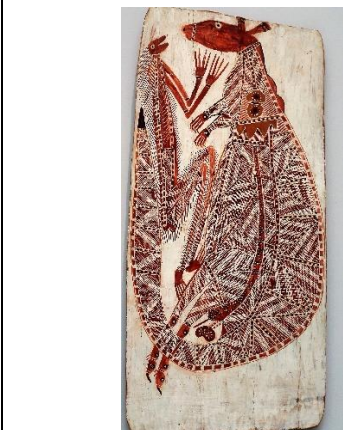

'Kundaagi - Red Plains Kangaroo' – Yirawala.

National Art Gallery. Continued...



The Sidney Nolan room.



Ian and Janet.



'The Evening' – Sidney Nolan.



'Ned Kelly' – Sidney Nolan.



'Death of Sergeant Kennedy at Stringybark Creek' – Sidney Nolan.



'Glenrowan' – Sidney Nolan.



'The Trial' – Sidney Nolan.



Canberra Botanical Gardens.

In the afternoon of the 13th of April, 2016, Ian, Janet and Mel, visited the Canberra Botanical gardens. This picture gallery is a random selection of sites in both the 'Rain Forest' and 'Red Centre' sections of the gardens (both within several hundred or so metres of each other). We had a guide which added great value to the tour...

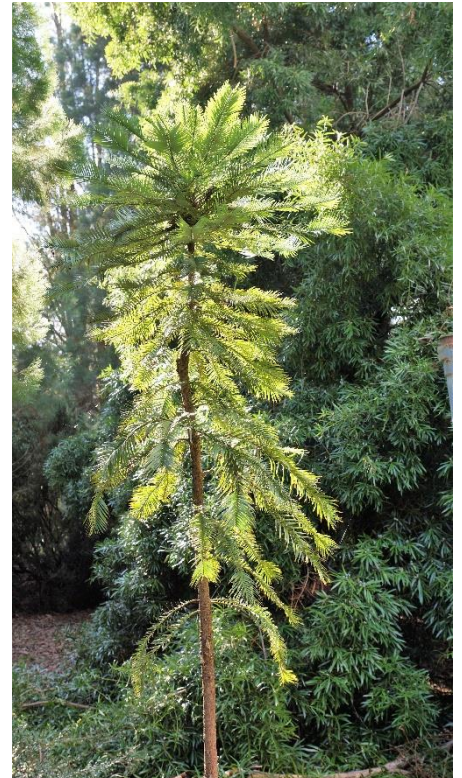
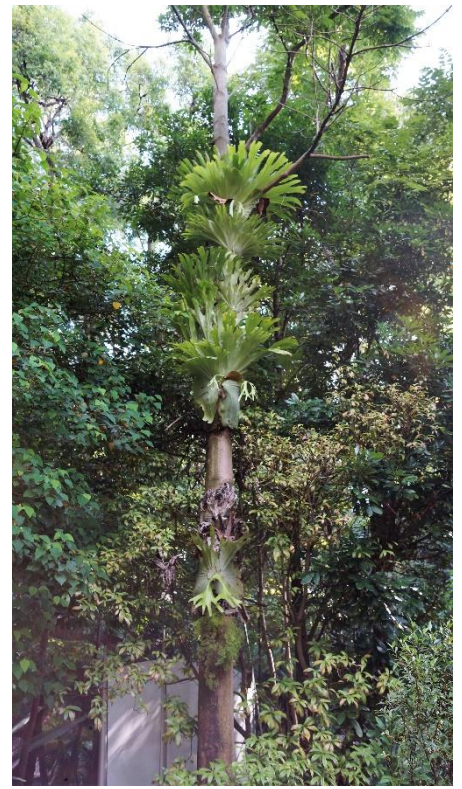
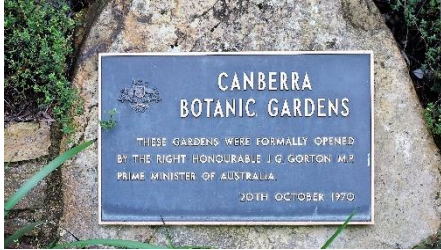

Wollemia nobilis – Wollemi Pine family ARAUCARIACEAE

Like finding a living dinosaur

When you discover a new species of dinosaur, you can't help but wonder about its appearance and how it lived. It's a bit like discovering a new species of plant. You have to look at the fossil record and try to reconstruct the plant's appearance and how it lived. It's a bit like finding a living dinosaur.

At 150 km from the heart of Canberra, the protected wilderness of Wollemi National Park hides its secrets well.



Welcome to the
RED CENTRE GARDEN

Allocasuarina decasneana Desert Oak
 irrkepe arrkepe kurkkapi
 kurrkara kurkapi kurkaça intarra
 kurpa kurkara nyirripi ujarangu
 witiirpa yintarra yujarrangu tatu



Devils in the Desert

Australia is home to many amazing animals, but one of the most bizarre looking is a spiny lizard known as the Thorny Devil (*Moloch horridus*).

Drink up

The Thorny Devil drinks like no other lizard. A system of tiny grooves between its scales channels water from all over its body to the Thorny Devil's mouth. It can drink water by just standing in the rain or from dew that settled on its body overnight.



Farmers Market – Saturday 16th April, 2016, at EPIC (Exhibition Park in Canberra)

Janet and Mel made an early 5 minute, morning walk across EPIC to the market to stock up for the weekend.



Canberra Lapidary Club Rock Swap – EPIC, Canberra, ACT.

Held on Saturday 16th and Sunday 17th of April, 2016, and attended by Ian, Janet and Mel. Another successful rock swap with mostly the same players (camper/traders) and more day traders than usual. Some good early sales were made on Friday (before the show) followed by a steady flow of buyers on Saturday, but a bit quieter on the Sunday. Ian was trading; Janet and Mel were his assistants. Ian was happy with his sales and he made some nice quartz purchases as well; some appear in this newsletter, but the bigger specimens will be featured in the June newsletter. The following photo gallery is made up of random clips of the show and its traders...



All set up to trade – view south.



Partners trade their own craft; not necessarily rocks or lapidary.



What child wouldn't love one of these?



This chap has been having a ball!



Greg always has a good range of rocks, minerals and lapidary.



Rocks, minerals, trinkets, etcetera.



Michael and Coralie attract a lot of interest with their range.



Steady interest from the public.



Terry having a break and chat away from his stall.



Canberra Lapidary Club Information team.



Ian's stall extends across two vans.



‘Cirque Africa’ at EPIC.

On the 16th of April, 2016, Ian, Janet and Mel, attended the evening session of ‘Cirque Africa’. We thoroughly enjoyed the show and we recommend you attend if the opportunity arises. It is quite amazing what people can do physically with persistent training and practise. Regular cameras were not permitted, but phone cameras were okay providing they did not flash or inhibit anyone’s view. This picture gallery depicts a random selection of only several acts...

Winston Ruddle presents
CIRQUE AFRICA
THE GREATEST SHOW FROM AFRICA
CHILDREN FREE!
THE WORLD'S BEST
AFRICAN CIRCUS ACTS FROM 6 COUNTRIES
BACKED BY LIVE ORCHESTRA
WITH EQUAL AMOUNT OF PAYING MEMBERS
Offer valid on FRIDAY'S only
100% AFRICAN ENERGY FUN
7 APRIL - 29 MAY 2016
Exhibition Park - CANBERRA
Flemington Rd & Northbourne Avenue
Mitchell ACT 2602 IN A BIG TOP TENT
TICKETEK Book now at ticketek.com.au Preview at cirqueafrica.com.au

CIRQUE AFRICA UNIQUE ENTERTAINMENTS PTY LTD PRESENTS
CIRQUE AFRICA
GREATEST AFRICAN SHOW
Sat 16 Apr 2016 7:30pm
VIP ELEVATED CHAIRS
SECTION 2 ROW 6 SEAT 7
DOOR 1 SECTION 2 ROW / SEAT G 7
COMP SCOMP IN SET
NAME: IAN WATSON PURCHASED: IAN WATSON SELLER: IAN WATSON



Contributed by Doug Walker...

Aphorisms

1. The nicest thing about the future is that it always starts tomorrow.
2. Money will buy a fine dog but only kindness will make him wag his tail.
3. If you don't have a sense of humour you probably don't have any sense at all.
4. Seat belts are not as confining as wheelchairs.
5. A good time to keep your mouth shut is when you're in deep water.
6. How come it takes so little time for a child who is afraid of the dark to become a teenager who wants to stay out all night?
7. Business conventions are important because they demonstrate how many people a company can operate without.
8. Why is it that at class reunions you feel younger than everyone else looks?
9. Stroke a cat and you will have a permanent job.
10. No one has more driving ambition than the teenage boy who wants to buy a car.
11. There are no new sins; the old ones just get more publicity.
12. There are worse things than getting a call for a wrong number at 4 a.m. - for example, it could be the right number.
13. No one ever says "It's only a game" when their team is winning.
14. I've reached the age where 'happy hour' is a nap.
15. Be careful about reading the fine print there's no way you're going to like it.
16. The trouble with bucket seats is that not everybody has the same size bucket.
17. Do you realise that, in about 40 years, we'll have thousands of old ladies running around with tattoos?
18. Money can't buy happiness but somehow it's more comfortable to cry in a Cadillac than in a Ford.
19. After 60, if you don't wake up aching in every joint, you're probably dead.
20. Always be yourself because the people that matter don't mind and the ones that mind don't matter.
21. Life isn't tied with a bow but it's still a gift.

☺☺☺

Contributed by Doug Hughes...

Kilroy Was Here!

Did you wonder who "Kilroy" was.

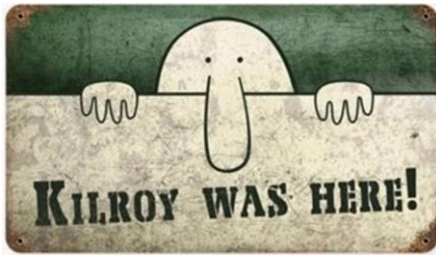

He is engraved in stone in the National War Memorial in Washington, DC, back in a small alcove where very few people have seen it. For the WWII generation, this will bring back memories. For you younger folks, it's a bit of trivia that is a part of our American history. Anyone born in 1913 to about 1950, is familiar with Kilroy. No one knew why he was so well known, but everybody seemed to get into it.

So who was Kilroy?



In 1946 the American Transit Association, through its radio program, "Speak to America," sponsored a nationwide contest to find the real Kilroy, offering a prize of a real trolley car to the person who could prove himself to be the genuine article. Almost 40 men stepped forward to make that claim, but only James Kilroy from Halifax, Massachusetts, had evidence of his identity.



'Kilroy' was a 46-year old shipyard worker during the war who worked as a checker at the Fore River Shipyard in Quincy. His job was to go around and check on the number of rivets completed. Riveters were on piecework and got paid by the rivet. He would count a block of rivets and put a check mark in semi-waxed lumber chalk, so the rivets wouldn't be counted twice. When Kilroy went off duty, the riveters would erase the mark.

Later on, an off-shift inspector would come through and count the rivets a second time, resulting in double pay for the riveters.



One day Kilroy's boss called him into his office. The foreman was upset about all the wages being paid to riveters, and asked him to investigate. It was then he realized what had been going on. The tight spaces he had to crawl in to check the rivets didn't lend them-selves to lugging around a paint can and brush, so Kilroy decided to stick with the waxy chalk. He continued to put his check mark on each job he inspected, but added 'KILROY WAS HERE' in king-sized letters next to the check, and eventually added the sketch of the chap with the long nose peering over the fence and that became part of the Kilroy message.

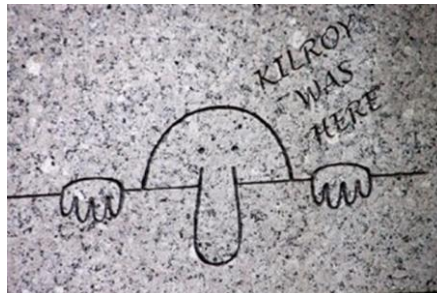

Once he did that, the riveters stopped trying to wipe away his marks. Ordinarily the rivets and chalk marks would have been covered up with paint. With the war on, however, ships were leaving the Quincy Yard so fast that there wasn't time to paint them. As a result, Kilroy's inspection "trademark" was seen by thousands of servicemen who boarded the troopships the yard produced.



His message apparently rang a bell with the servicemen, because they picked it up and spread it all over Europe and the South Pacific.



Before war's end, "Kilroy" had been here, there, and everywhere on the long hauls to Berlin and Tokyo. To the troops outbound in those ships, however, he was a complete mystery; all they knew for sure was that someone named Kilroy had "been there first." As a joke, U.S. servicemen began placing the graffiti wherever they landed, claiming it was already there when they arrived.

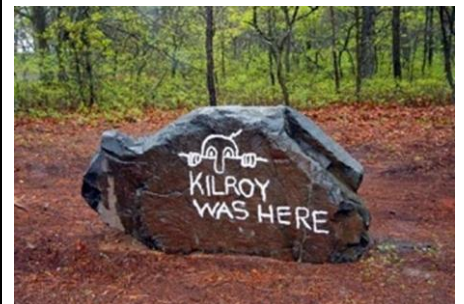

Kilroy became the U.S. super-GI who had always "already been" wherever GIs went. It became a challenge to place the logo in the most unlikely places imaginable it is said to be atop Mt. Everest, the Statue of Liberty, the underside of the Arc de Triomphe, and even scrawled in the dust on the moon.



As the war went on, the legend grew. Underwater demolition teams routinely sneaked ashore on Japanese-held Islands in the Pacific to map the terrain for coming invasions by U.S. troops (and thus, presumably, were the first GIs there). On one occasion, however, they reported seeing enemy troops painting over the Kilroy logo!

Continued next page...

Kilroy Was Here!

Continued...



In 1945, an outhouse was built for the exclusive use of Roosevelt, Stalin, and Churchill at the Potsdam conference. Its first occupant was Stalin, who emerged and asked his aide (in Russian), "Who is Kilroy?"



To help prove his authenticity in 1946, James Kilroy brought along officials from the shipyard and some of the riveters. He won the trolley car, which he gave to his nine children as a Christmas gift and set it up as a playhouse in the Kilroy yard in Halifax, Massachusetts.



And The Tradition Continues...



EVEN Outside Osama Bin Laden's House!!!

From Wikipedia, the free encyclopedia...

https://en.wikipedia.org/wiki/Kilroy_was_here

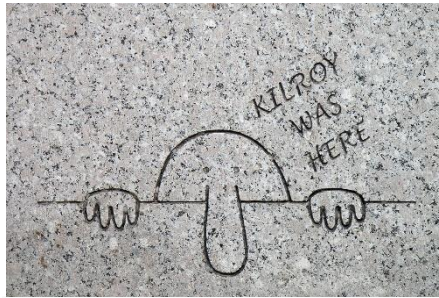

Engraving of Kilroy on the WWII Memorial in Washington, D.C.

This article is about the graffiti. For the Styx album, see Kilroy Was Here (album).

Kilroy was here is an American popular culture expression that became popular during World War II; it is typically seen in graffiti. Its origins are debated, but the phrase and the distinctive accompanying doodle — a bald-headed man (sometimes depicted as having a few hairs) with a prominent nose peeking over a wall with the fingers of each hand clutching the wall — became associated with GIs in the 1940s.

In the United Kingdom, the graffiti is known as "**Mr Chad**" or just "**Chad**", and the Australian equivalent to the phrase is "**Foo was here**". "Foo was here" might date from World War I, and the character of Chad may have derived from a British cartoonist in 1938, possibly pre-dating "Kilroy was here". Etymologist Dave Wilton says, "Sometime during the war, Chad and Kilroy met, and in the spirit of Allied unity merged, with the British drawing appearing over the American phrase. "Foo was here" became popular amongst Australian schoolchildren of post-war generations. Other names for the character include Smoe, Clem, Flywheel, Private Snoops, Overby, The Jeep (as both characters had sizable noses), and Sapo.

Author, Charles Panati, says that in the United States "the mischievous face and the phrase became a national joke. The outrageousness of the graffiti was not so much what it said, but where it turned up. "The major Kilroy graffiti fad ended in the 1950s, but today people all over the world still scribble the character and "Kilroy was here" in schools, trains, and other public areas.

It is believed that [James J. Kilroy](#) was the origin of the expression, as he used the phrase when checking ships at the *Fore River Shipyard*.



Contributed by Doug Walker...

I Want Four Little Animals

(Mama taught her well! You've got to love this little girl. What a woman she'll make.)

A teacher asked her class, "What do you want out of life?" A little girl in the back row raised her hand and said, "All I want out of life is four little animals, just like my Mom always says".

The teacher asked, "Really and what four little animals would that be?"

The little girl said, "A mink on my back, a jaguar in the garage, a tiger in the bed and a jackass to pay for all of it!"

The teacher got a coughing fit and had to leave the room.



Contributed by Doug Walker...

Can Cold Water Clean Dishes?

(This is for all the germ conscious folk who worry about using cold water to clean.)

John went to visit his 90-year-old grandfather in a very secluded, rural area of Saskatchewan. After spending a great evening chatting the night away, the next morning John's grandfather prepared breakfast of bacon, eggs and toast.

However, John noticed a film like substance on his plate, and questioned his grandfather asking, 'Are these plates clean?' His grandfather replied, 'They're as clean as cold water can get em. Just you go ahead and finish your meal, Sonny!'

For lunch the old man made hamburgers. Again, John was concerned about the plates, as his appeared to have tiny specks around the edge that looked like dried egg and asked, 'Are you sure these plates are clean?' Without looking up the old man said, 'I told you before, Sonny, those dishes are as clean as cold water can get them. Now don't you fret, I don't want to hear another word about it!'

Later that afternoon, John was ready to proceed to a nearby town and as he was leaving, his grandfather's dog started to growl, and wouldn't let him pass. John yelled and said, 'Grandfather, your dog won't let me get to my car'. Without diverting his attention from the football game he was watching on TV, the old man shouted, 'Coldwater, go lay down now, yah hear me!'



Meet Cold Water.

'Fifty Shades of Chocolate!'



Mr *Cadbury*



met Miss *Rowntree*



on a *Double Decker*.



It was just *After Eight*.



They got off at *Quality Street*. Then he asked her, 'What is your name?'



My name is *'Polo*, I'm the one with the hole',



she said, with a *Wispa*.



I'm *Marathon*, the one with the nuts, he replied.



He touched her *Creme Eggs*,



which was a *Kinder Surprise* for her.



Then he slipped his hand into her *Snickers*,



which made her *choc Ripple*.



He fondled her *Jelly Babies*,



and she rubbed his *Tic Tacs*.



Soon they were *Heart Throbs*.



It was a *Fab* moment,



so she screamed in *Turkish Delight*.



But, 3 days later, his *Sherbet Dip Dab* started to itch.

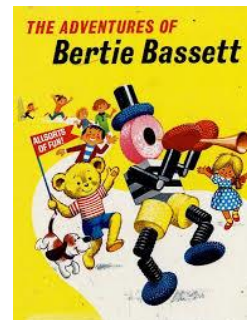

It turns out Miss Rowntree had been out with *Bertie Bassett* and he had *Allsorts*.